



Precision's durable all stainless steel cabinets have been designed to provide commercial caterers with reliable, energy and cost efficient refrigerated storage solutions. Proudly made in the UK, these slimline cabinets are capable of meeting the highest demands of commercial kitchens all around the world - especially when space is at a premium.



Non-Gastronorm Shelving System With Anti-Tilt Slides

Key Features:

Stainless Steel Interior & Exterior

Designed To Operate In 43°C Ambient

Built-In Air Rear Duct For Even Temperature Distribution

R290 Hydrocarbon Refrigerant

Zero ODP Injected Polyurethane Insulation - 60mm

-2 / +4°C Refrigerator Temperature Range

Electronic Controller With Easy Read LCD Screen

Door Locks Fitted As Standard

Rifle Bore Coated Evaporators

Ergonomic Flush Door Handle

Non Gastronorm Shelving System - (GN1/1 Pans Can Fit On Shelves) - Anti Tilt Slides

Hi / Lo Audio Visual Temperature Alarms

Condensing Unit Safety System To Protect Compressor From Blocked Condensers

Self Closing Doors

Heavy Duty Brake & Swivel Castors

Waste Heat Recovery Condensate Vaporiser System

Options:

Extra Std Nylon Coated Shelves / Slides

Extra Shelf / Pan Slides

Fish Shelving - 7 x GN1/1 - 100mm Deep - Stainless Steel Pans & Slides per section with Slime Trays

Stainless Steel Back

Left Hand Hinged Door

Adjustable Legs

Remote - Excludes Condensing Unit But Includes R452A Expansion and Solenoid Valve (Fitted)

Precision Connect

Distributor:

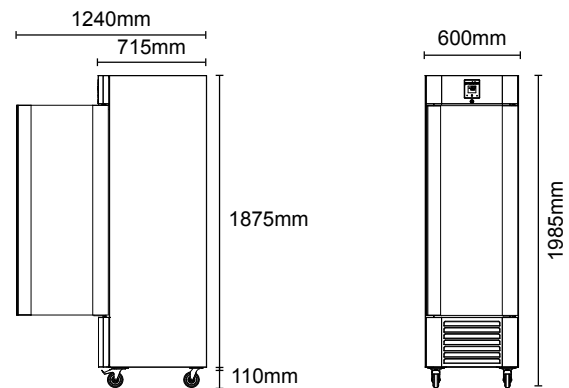

| Model | MPU401 | LPU401 |
|---|---------------|---------------|
| Type | Refrigerator | Freezer |
| Material | ST/ST Int/Ext | ST/ST Int/Ext |
| Shelf Size | 418 x 530mm | 418 x 530mm |
| Number of Shelves | 3 | 3 |
| Max Number of Shelves (100mm Spacing) | 9 | 9 |
| Temperature Range | -2 / +4°C | -18 / -22°C |
| Exterior WxDxH (mm) | 600x715x1985 | 600x715x1985 |
| Net Usable Volume (litres) | 261 | 261 |
| Weight (KG) | 110 | 120 |
| Refrigerant / GWP | R290 /3 | R290 /3 |
| Refrigeration Watts (+45°C Condensing) | 373 | 495 |
| Evaporating Temp | -10°C | -30°C |
| Heat Rejection Watts* | 571 | 928 |
| Noise Output (dBA) | 67 | 69 |
| Power | 230 / 50 / 1 | 230 / 50 / 1 |
| Running Amps | 1.3 | 2.9 |
| Total Electrical Load - kW | 0.30 | 0.67 |
| Energy Consumption / 24hrs - kWh** | 1.14 | 6.03 |
| Energy Consumption / Year (AEC) - kWh** | 416 | 2200 |
| Energy Efficiency Class** | C | E |

* Heat Rejection is taken at the listed evaporating and condensing condition. Watts is calculated by taking the total power of the cabinet.

** Tested to EN16825

We are constantly innovating and improving our products. Please always check our website for the most up-to-date version of this spec sheet

Distributor:

KiD Catering Equipment, Oaktree Court Business Centre, Mill Lane, Ness, Cheshire, CH64 8TP
Tel: 0333 123 2450 sales@kidcateringequipment.com